

WEAVER[®] JACK CORP.

**M O D E L W A - 7 5 A
&
M O D E L W A - 7 5 B**

PARTS BREAKDOWN SERVICE MANUAL

FOR PARTS, PLEASE CONTACT:

Castle EQUIPMENT
COMPANY
SINCE 1950

TOLL-FREE: 888-274-8490

TELEPHONE: 815-458-6216

FAX: 815-458-9350

E-MAIL: CASTLE@AMERITECH.NET

WEBSITE: WWW.CASTLEEQUIPMENT.COM

P.O. Box 3; BRAIDWOOD, IL 60408

MODEL WA-75A

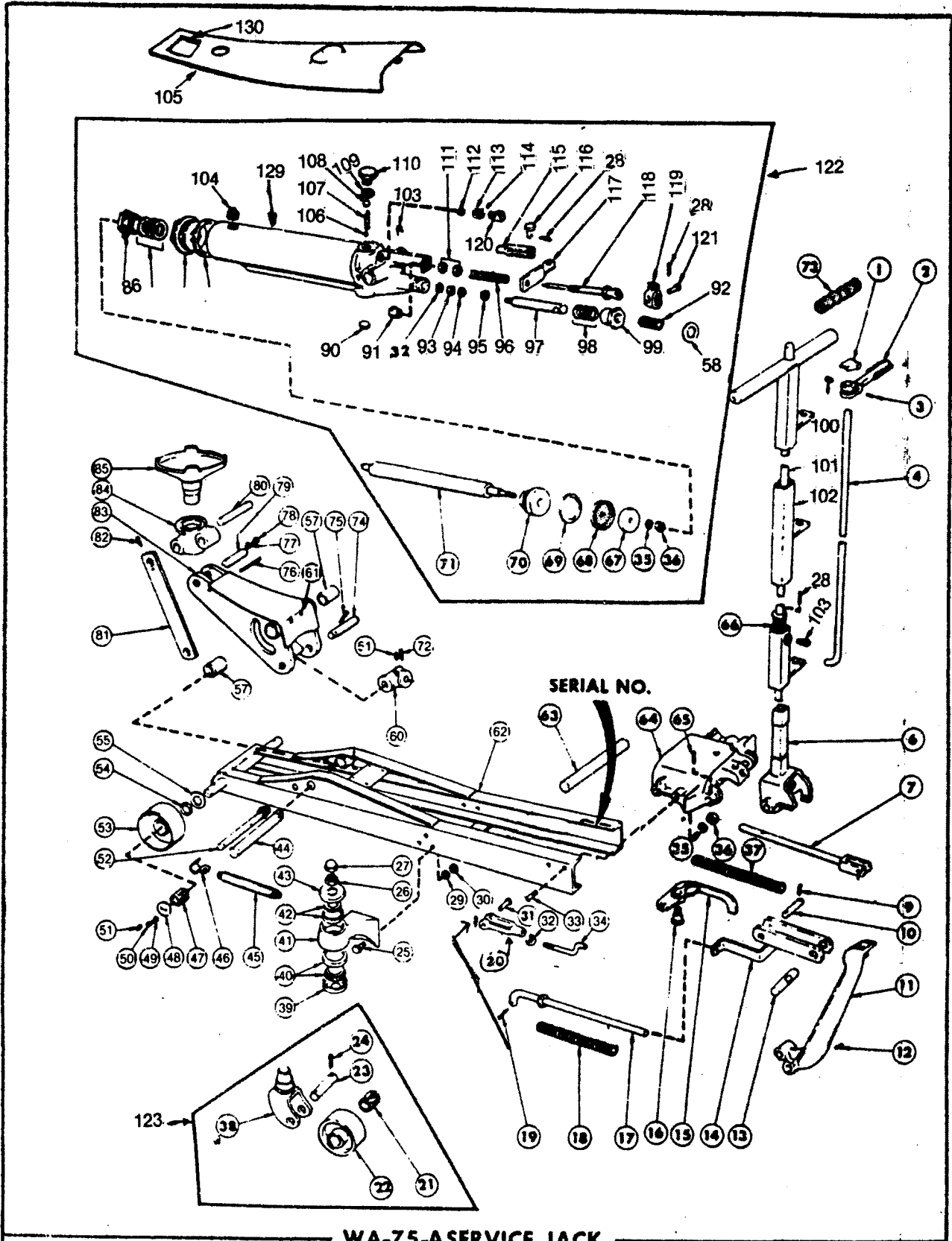

WA-75-A SERVICE JACK

NOTE

Always specify correct part number as well as model and serial number of your unit when ordering parts.

Repair Parts List WA-75-A

Item No.	Part No.	Description	Item No.	Part No.	Description
1.	S-7075	Release Lock	70.	M-1154-1	Ram Head
2.	M-1157	Release Handle	71.	S-24709	Piston Rod
3.	S-23689	Roll Pin	72.	S-3083	Cotter Pin 3/16 x 2-3/4
4.	S-5261	Release Rod	73.	S-20886	Handle Grip
5.			74.	S-24707	Crosshead Pin
6.	M-1414	Handle Yoke	75.	S-3234	Cotter Pin 3/16 x 2
7.	AS-20415	Return Guide Assembly	76.	S-6577	Sector Spring Key
8.			77.	S-10189	Lockwasher 1/4" Int.
9.	S-107	Cotter Pin 1/8 x 1	78.	S-160	Mach. Screw 1/4-20 NC x 3/8
10.	S-24659	Clevis Pin	79.	S-6580	Lifting Arm Pin
11.	M-1416	Foot Lever Pin	80.	S-5158	Parallel Arm Pin
12.	S-23872	Set Screw 1/4 NC x 5/8	81.	S-24651	Parallel Arm
13.	S-6552	Foot Lever Pin	82.	S-16099	Cotter Pin 3/16 x 2-1/4
14.	AS-9785	Pump Link Assembly	83.	AS-24654	Lifting Arm Assembly
15.	M-1148	Release Lever	84.	M-1433-1	Saddle Bracket
16.	S-6586	Release Lever Pin	85.	M-1159	Saddle
17.	S-27384	Plunger Return Rod	86.	M-1427	Piston Packing Nut
18.	S-9786	Plunger Return Spring	87.	S-6615	Piston Rod Packing
19.	S-275	Cotter Pin 1/8 x 3/4	88.	M-1426	Cylinder Cap
20.	S-5123	Clevis	89.	S-22963	Gasket
21.	S-15398	Roller Bearing	90.	S-2497	Welch Plug
22.	M-1152-1	Caster Wheel	91.	S-5173	Release Valve Guide
23.	S-711	Caster Axle	92.	S-8624	Lever Friction Spring
24.	S-293	Cotter Pin 3/16 x 1	93.	S-7413	Pump Leather Washer
25.	S-24751	12 Pt. Cap Screw 1/2-20 UNF x 1-1/4	94.	S-24648	Pump Cup Leather
26.	S-2232	Hex Jam Nut 3/4-16 UNF	95.	S-24690	Ring
27.	S-6605	Hex Acorn Nut	96.	S-2591	Release Spring
28.	S-4074	Cotter Pin 1/16 x 3/4	97.	S-24497	Pump Plunger
29.	S-3008	Int. Lockwasher 1/2	98.	S-7412	Plunger Packing
30.	S-9522	Hex Nut 1/2-20 UNF	99.	M-1167	Pump Packing Nut
31.	S-4710	Release Yoke Pin	100.	S-23872	Sq. Hd. Set Screw 1/4 UNC x 3/4
32.	S-1863	Hex Nut 5/16-24 UNF	101.	AS-6550	Lock Rod Assembly
33.	S-5014	Cap Screw 1/2-13 NC x 2-3/4	102.	AS-6660	Handle Assembly
34.	S-6576	Release Pull Rod	103.	S-102	Sq. Hd. Set Screw 1/4 UNC x 3/4
35.	S-512	Lockwasher 1/2	104.	S-5178	Filler Plug
36.	S-508	Hex Nut 1/2-13 UNC	105.	AS-12393	Cover Plate
37.	S-1365	Return Spring	106.	S-3282	Ball 7/16"
38.	M-2030	Caster Yoke	107.	S-5355	Intake Ball Weight
39.	S-15429	Stamped Closure	108.	S-5122	Ball 5/8"
40.	AS-15815	Lower Bearing Assembly	109.	S-5125	Plug Gasket
41.	M-2028	Caster Bracket	110.	S-5171	Ball Chamber Plug
42.	AS-15814	Upper Bearing Assembly	111.	S-1934	Hex Jam Nut 3/8-16 UNC
43.	S-24650	Caster Bearing Cap	112.	S-15047	O-Ring
44.	S-28009	Sector Pin	113.	S-21051	Packing
45.	S-6603	Sector Spring	114.	S-17829	O-Ring 3/8"
46.	S-5127	Spring Hook	115.	S-4821	Plunger Rod Yoke
47.	S-11103	Front Wheel Bearing	116.	S-4710	Pin
48.	S-9147	Front Wheel Retainer	117.	S-24685	Release Link
49.	S-543	Lockwasher 1/4"	118.	AS-24684	Release Valve Assembly
50.	S-1877	Cap Screw 1/4-20 NC x 3/4	119.	S-7180	Needle Extension
51.	S-5096	Grease Zerk 1/8 N.P.T.	120.	S-5176	Release Packing Nut
52.	S-28008	Parallel Bar Pin	121.	S-4710	Pin, Clevis
53.	AS-12588	Front Wheel Assembly	122.	AS-24691	Pump Assembly (Complete)
54.	S-5200	Inside Hub Washer	123.	AS-24621	Caster Assembly (Includes Items 21, 22, 23, 24, 38).
55.	S-9149	Inside Wheel	124.	AS-6545	Handle Assembly (Includes Items 1, 3, 4, 12, 28, 66, 100, 101, 102, 103).
56.	S-24687	Limit Rod	125.	AS-24494	Piston Rod Assembly (Includes Items 35, 36, 67, 68, 69, 70, 71).
57.	S-6592	Bushing	126.	AS-24498	Pump Plunger Assembly (Includes Items 32, 93, 94, 95, 97).
58.	S-19990	Lever Spring Washer	127.	AS-21052	Packing Assembly (Includes Items 112, 113, 114).
59.	S-1878	Hex Nut 1/4-28 UNF	128.	AS-22107	Release Handle Assembly (Includes Items 1, 2, 3, 100).
60.	M-1158	Crosshead	129.	AS-24485	Cylinder Shell
61.			130.	S-28082	Name Plate
62.	AS-24658	Frame Assembly			
63.	S-24705	Cylinder Pin			
64.	M-1423	Tie Casting			
65.	S-15694	Roll Pin			
66.	S-2329	Lock Return Spring			
67.	S-5181	Ram Cup Washer			
68.	S-24649	Ram Cup			
69.	S-24703	Ring			

MODEL WA-75B

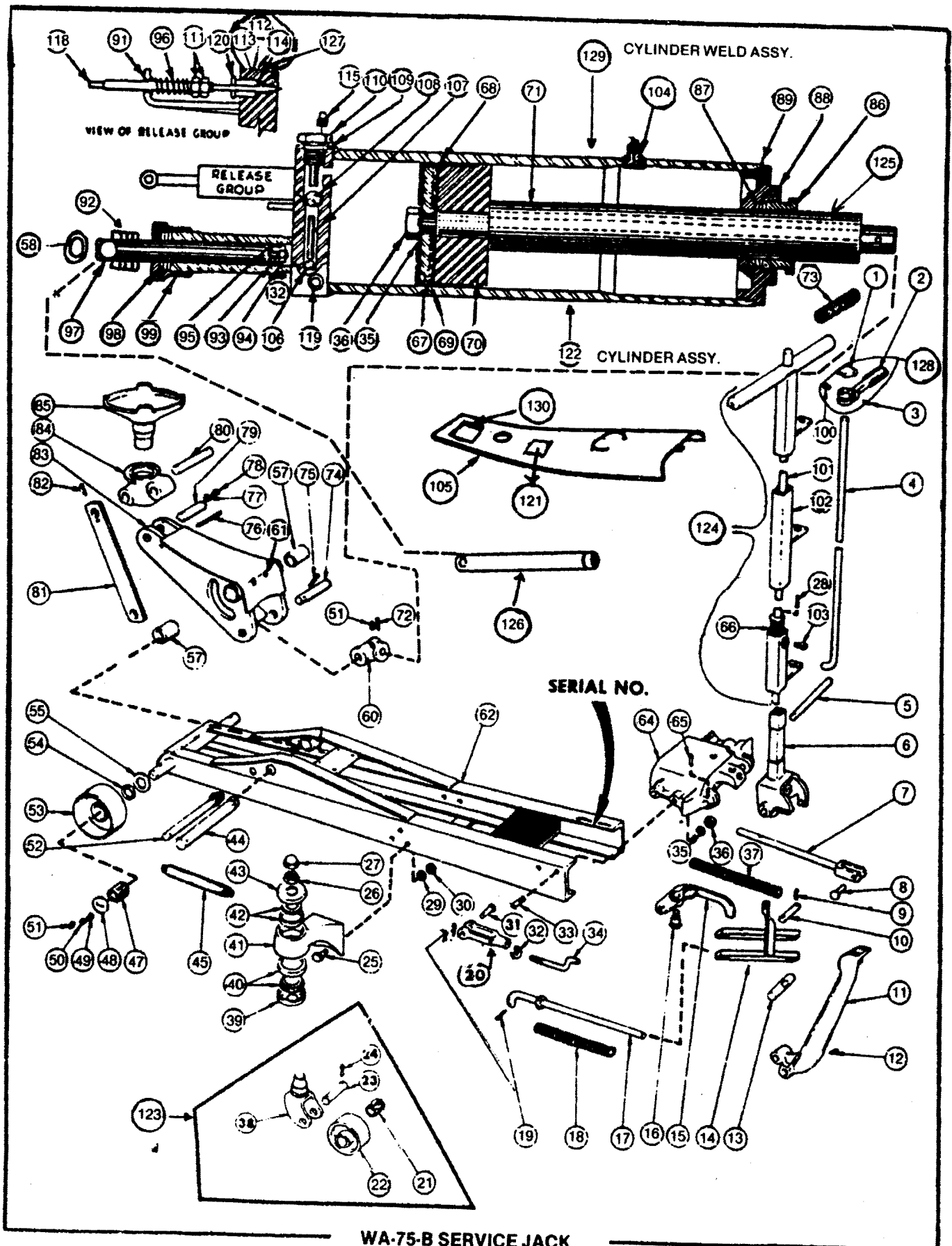

WA-75-B SERVICE JACK

NOTE

Always specify correct part number as well as model and serial number of your unit when ordering parts.

Repair Parts List WA-75B

Item No.	Part No.	Description	Item No.	Part No.	Description
1.	S-7075	Release Lock	69.	S-24703	Ring
2.	M-1157	Release Handle	70.	M-1154	Ram Head
3.	S-23689	Roll Pin	71.	S-24709	Piston Rod
4.	S-5261	Release Rod	72.	S-3083	Cotter Pin 3/16 x 2-3/4
5.	S-6551	Handle Pin	73.	S-20886	Handle Grip
6.	M-1414	Handle Yoke	74.	S-24707	Crosshead Pin
7.	AS-20495	Return Guide Assembly	75.	S-3234	Cotter Pin 3/16 x 2
8.	S-5263	Handle Return Pin	76.	S-6577	Sector Spring Key
9.	S-107	Clevis Pin	77.	S-10189	Lockwasher 1/4" Int.
10.	S-24659	Clevis Pin	78.	S-160	Mach. Screw 1/4-20 NC x 3/8
11.	M-1416	Foot Lever	79.	S-6580	Lifting Arm Pin
12.	S-5098	Set Screw 1/4 NC x 5/8	80.	S-5158	Parallel Arm Pin
13.	S-6552	Foot Lever Pin	81.	S-24651	Parallel Arm
14.	M-2237	Pump Link Assembly	82.	S-16099	Cotter Pin 3/16 x 2-1/4
15.	M-1148	Release Lever	83.	AS-24654	Lifting Arm Assembly
16.	S-6586	Release Lever Pin	84.	M-1433	Saddle Bracket
17.	S-27385	Plunger Return Rod	85.	M-1159	Saddle
18.	S-9786	Plunger Return Spring	86.	M-1427	Piston Packing Nut
19.	S-275	Cotter Pin 1/8 x 3/4	87.	S-6615	Piston Rod Packing
20.	S-5123	Release Clevis	88.	M-1426	Cylinder Cap
21.	S-15398	Roller Bearing	89.	S-22963	Gasket
22.	M-1152	Caster Wheel	90.		
23.	S-711	Caster Axle	91.	S-5173	Release Valve Guide
24.	S-293	Cotter Pin 3/16 x 1	92.	S-8624	Lever Friction Spring
25.	S-24751	12 Pt. Cap Screw 1/2-20UNF x 1-1/4	93.	S-7413	Back-up Washer
26.	S-2232	Hex Jam Nut 3/4-16 UNF	94.	S-24648	Pump Cup Leather
27.	S-6605	Hex Acorn Nut 3/4-16 UNF	95.	S-24690	Ring
28.			96.	S-2591	Release Spring
29.	S-3008	Int. Lockwasher 1/2	97.	S-24497	Pump Plunger
30.	S-9522	Hex Nut 1/2-20 UNF	98.	S-7412	Plunger Packing
31.	S-4710	Release Yoke Pin	99.	M-1167	Pump Packing Nut
32.	S-1863	Hex Nut 5/16-24 UNF	100.	S-23872	Sq. Hd. Set Screw 1/4UN x 3/4
33.	S-5014	Cap Scw. 1/2-13 NC x 2-3/4	110.	AS-6550	Lock Rod Assembly
34.	S-6576	Release Pull Rod	102.	AS-6660	Handle Assembly
35.	S-512	Lockwasher 1/2	103.	S-102	Sq. Hd. Set Screw 3/8 UNC x 3/4
36.	S-508	Hex Nut 1/2-13 UNC	104.	S-5178	Filler Plug
37.	S-1365	Return Spring	105.	AS-12393	Cover Plate
38.	M-2030	Caster Yoke	106.	S-3282	Ball 7/16"
39.	S-15429	Stamped Closure	107.	S-5355	Intake Ball Weight
40.	AS-15815	Lower Bearing Assembly	108.	S-5122	Ball 5/8"
41.	M-2028	Caster Bracket	109.	S-5125	Plug Gasket
42.	AS-15814	Upper Bearing Assembly	110.	S-16196	Ball Chamber Plug
43.	S-24650	Caster Bearing Cap	111.	S-1934	Hex Jam Nut 3/8-16 UNC
44.	S-28009	Sector Pin	112.	S-15047	O-Ring 1/4"
45.	S-6603	Sector Spring	113.	S-21051	Packing Housing
46.			114.	S-17829	O-Ring 3/8"
47.	S-11103	Front Wheel Bearing	115.	S-1805	Pipe Plug 1/8"
48.	S-9147	Front Wheel Retainer	116.		
49.	S-543	Lockwasher 1/4"	117.		
50.	S-1877	Cap Screw 1/4-20 NC x 3/4	118.	S-21050	Release Valve
51.	S-5096	Grease Zerk 1/8 N.P.T.	119.	S-5652	Pipe Plug 3/8"
52.	S-24706	Parallel Bar Pin	120.	S-5176	Release Packing Nut
53.	AS-12588	Front Wheel Assembly	121.	S-24747	Gcv't Plate
54.	S-5200	Inside Hub Washer	122.	AS-24691A	Cylinder Assembly
55.	S-9149	Inside Wheel Washer	123.	AS-24621	Caster Assembly (Includes Items 21, 22, 23, 24, 38).
56.			124.	AS-6545	Handle Assembly (Includes Items 1, 3, 4, 12, 28, 66, 100, 101, 102, 103).
57.	S-6592	Bushing	125.	AS-24494	Piston Rod Assembly (Includes Items 35, 36, 67, 68, 69, 70, 71).
58.	S-19990	Lever Spring Washer	126.	AS-24498	Pump Plunger Assembly (Includes Items 32, 93, 94, 95, 97).
59.			127.	AS-21052	Packing Assembly (Includes Items 112, 113, 114).
60.	M-1158	Crosshead	128.	AS-22107	Release Handle Assembly (Includes Items 1, 2, 3, 100).
61.	S-6593	Lift Arm Bushing Retainer	129.	AS-24485A	Cylinder Shell
62.	AS-24658A	Frame Assembly	130.	S-28082	Name Plate
63.					
64.	M-1423	Tie Casting			
65.	S-15694	Roll Pin			
66.	S-2329	Lock Return Spring			
67.	S-5181	Ram Cup Washer			
68.	S-24649	Ram Cup			

KJ-108 Seal Kit

For Weaver WA-75A and WA-75B 10 Ton Jack

Contains:

S-5122	Ball
S-3282	Ball
S-15047	O Ring
S-17829	O Ring
S-24648	Pump Cup
S-24649	Piston Cup
S-22963	Gasket
S-7412	Packing (3)
S-6615	Packing (3)
S-24703	Teflon Ring
S-3083	Cotter Pin
S-5125	Aluminum Gasket

Order part number: KJ-108

Service Instructions

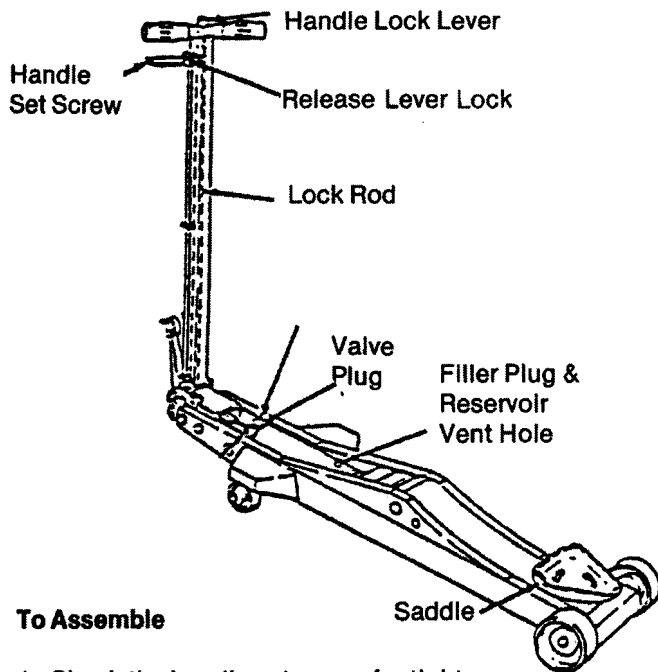

To Assemble

1. Check the handle set screw for tightness.
2. Remove and discard the vent filler plug. This is very important, as the vent hole must always be kept open so the jack can "breathe."

To Operate

1. The jack is easily maneuvered by depressing the Handle Lock Lever until the lock rod engages one of the two handle positions, and then pivoting the jack on its rear casters.
2. Place the jack in position so that the saddle will engage an approved lifting area of the vehicle. The saddle is raised to the contact point by the foot pedal. Light loads may be raised by the foot pedal alone. On low clearance vehicles it is often advantageous to operate the foot pedal by hand while watching to assure proper saddle contact. Surface on which jack rests should be fairly flat to prevent twisting of frame. Load should be centered in saddle.
3. Pump with handle for easy lifting. Do not attempt to raise jack beyond its travel stops.
4. To lower the load, pull back gently on the release lever.
5. Be certain that area beneath vehicle is clear before lowering vehicle. Always use the release lever lock to prevent unintentional operation of the release lever.

To Refill

Remove the filler plug and with the saddle DOWN put in MIL-F-17111 Oil until the level comes up to within 1/4" to 3/8" below filler hole. Overfilling causes oil to spurt out the vent hole as jack is lowered, or may prevent jack from lowering properly. Insufficient oil causes jack to lift only part way. Always be sure to put in oil only when the saddle is down. Be careful not to let any dirt get into the reservoir while the Filler Plug is out.

To Service

1. Keep all working parts thoroughly lubricated.
2. Packing nuts at the piston and pump plunger should be kept moderately tight. These packings are NOT under high pressure, and should only be tight enough to prevent leakage.
3. Ball valve may be removed for inspection and cleaning by removing the Ball Chamber Plug and turning the jack on its side, allowing the ball to roll out.

IMPORTANT: Whenever it is necessary to loosen or remove the Ball Chamber Plug, the gasket should be replaced with a new one. Oil leakage at this point is usually caused by trying to use an old gasket over again.

4. If pumping fails to raise the rated load, the lower ball valve is leaking, and it should be inspected for dirt or other obstruction. Also check for proper oil level.
5. If the load raises on the down stroke of the handle and immediately settles back, forcing the handle up, it shows the upper ball valve is leaking.

WARNING: Always use stands to support vehicle before attempting under vehicle repairs or inspections.

To Relieve When Air-Bound

1. Should the oil supply run too low, the jack may become air-bound and work on only a half stroke of the handle. Fill the jack with oil, raise the saddle, and then lower the saddle while holding the foot pedal depressed. This will flush out any air in the system, and excess oil may run out of the vent. Be sure jack is properly filled with oil before putting it back in service. Oil should cover piston rod.

To Remove Cylinder

1. Remove the cotter in the cross head.
2. Remove the cotter and pin in the pump.
3. Remove the cotter and pin in the release yoke.
4. Place cotter key in while depressing foot pedal. This allows for easy removal and reassembly if spring is left on return rod.
5. Raise the lifting arm by means of the saddle, and place a block of wood between the arm and frame to hold up the arm.
6. This releases the cylinder at the forward end, so that it may be removed as a complete unit, for service.

To Replace Cup

1. After removing the cylinder unit as described above, place it in a vise. Note that the vise jaws should grip the steel block, not the steel cylinder. Set the unit in the vise with the steel cylinder and piston up. Remove the vent plug.
2. Unscrew the cylinder cap and lift the piston out of the cylinder.
3. Remove the nut and washer which holds the cup at the end of the piston; put in the new cup, and replace nut and washer.
4. In fitting the new cup into the cylinder, USE GREAT CARE as the cup passes the filler plug hole not to cut or otherwise damage the cup. Then replace the cylinder cap.
5. To replace the small cup on the pump, turn the cylinder unit pump end upward in the vise.
6. Unscrew the packing nut and pull out the pump plunger. Remove the nut that holds cup to end of plunger, insert new cup, and replace nut.

Release Group Assembly Function

1. A means to manually release jack and safety overload circuit. If underloaded jack bleeds down, release valve may be out of alignment.
2. In release group assembly, spring governs load jack will lift. When pressure of cylinder overcomes spring tension the release valve floats off seat. It is imperative that the release valve floats freely in release group assembly. To check: use forefinger and thumb to grasp the release valve when the release clevis pin passes thru, and wiggle from side to side. There should be a minimum of .002 to .004 clearance. If no movement is noted, remove hex nut, release valve guide and release spring, and place release valve with release valve guide back in release nut. Tap end of release spring with Brass hammer. Slide release valve guide into position and noting where alignment is off, correct misalignment by tapping welded needle bracket accordingly with Brass hammer. Reassemble and set pressure by hydraulic means. *Note:* This procedure should only be done by a qualified Authorized Service Depot.

WEAVER[®] JACK CORP.

**M O D E L W A - 7 5 A
&
M O D E L W A - 7 5 B**

PARTS BREAKDOWN SERVICE MANUAL

FOR PARTS, PLEASE CONTACT:

Castle **EQUIPMENT**
COMPANY
 **SINCE 1950**

TOLL-FREE: 888-274-8490
TELEPHONE: 815-458-6216
FAX: 815-458-9350
E-MAIL: CASTLE@AMERITECH.NET
WEBSITE: WWW.CASTLEEQUIPMENT.COM
P.O. Box 3; BRAIDWOOD, IL 60408
